



Continuous Emission Monitoring

GCEM4000 Gas Analyser

CO, NO, NO₂, NO_x, SO₂, CH₄, HCl, N₂O, CO₂ & H₂O

In-situ, low maintenance devices for continuous process and emissions monitoring.

- Multi-species infrared absorption analyser - Accurate, reliable and low maintenance technology
- In-situ stainless steel probe measurement - No sample lines required
- Gas temperature and pressure sensors - On-board normalisation to standard reference conditions
- Auto routine calibration - Zero calibration by air, span calibration using audit gas
- Analogue and serial outputs - Export of data to SCADA, DCS and historian systems
- MCERTS Certified - Meets QAL1 of EN14181

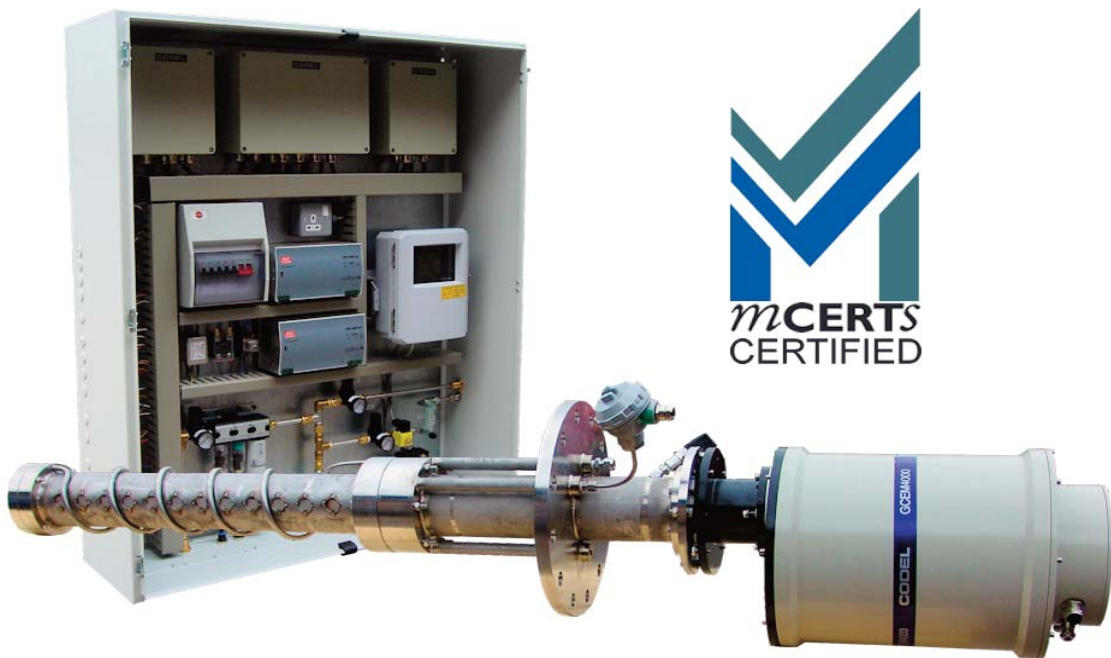

GCEM4000 Multi-Channel Gas Analyser

The GCEM4000 in-situ multi-gas analyser is CODEL's industry-proven continuous emissions monitor.

Three decades of development, knowledge and practical experience have been utilised to produce this advanced-technology gas analyser which gives complete flexibility of use on process or emissions applications whilst delivering superb accuracy and repeatability at a very competitive price.

The multi gas analyser uses an infra-red detector to measure hot exhaust gases without sampling or modification inside a porous probe positioned directly in the gas stream. The 316 stainless steel probe has been designed for the harshest stack conditions. It enables trouble-free measurement to be made even in very high dust level processes exceeding several gram/m³.

Designed for use primarily on combustion processes, the GCEM4000 measures key pollutants such as CO, NO, NO₂, NO_x, SO₂, CH₄, HCl, N₂O, CO₂ and H₂O using infra-red spectroscopy to ensure that there is no cross sensitivity from other contaminants in the gas stream.

Fully automated zero and span calibrations are performed using clean dry compressed air and protocol gas mixtures to provide long-term confidence with minimal maintenance. A locally mounted electrical/pneumatics CEMS Control Panel controls the manual, automatic or remote injection of zero and span gases directly into the measurement chamber. The CEMS Control Panel also provides a convenient location for on-site mounting of other associated electrical / pneumatic equipment. Manufactured with an integral thermo-electric peltier cooled weather cover to ensure a stable operating temperature for the sensing head in all climate conditions from -20°C to +50°C.

The GCEM4000 analyser is available with either a single species measurement for simple process control or with multiple species for complex emissions monitoring.

All models are fitted with probe-mounted:

- > temperature sensor
- > absolute pressure sensor

If H₂O and CO₂ (or separate O₂) are measured, the analyser can compute fully normalised data directly in mg/Nm³.



Peltier Cooled Weather Cover



GCEM4000 CEMS Control Panel



Stainless Steel 316l Probe

GCEM4000 Multi-Channel Gas Analyser - System Arrangement

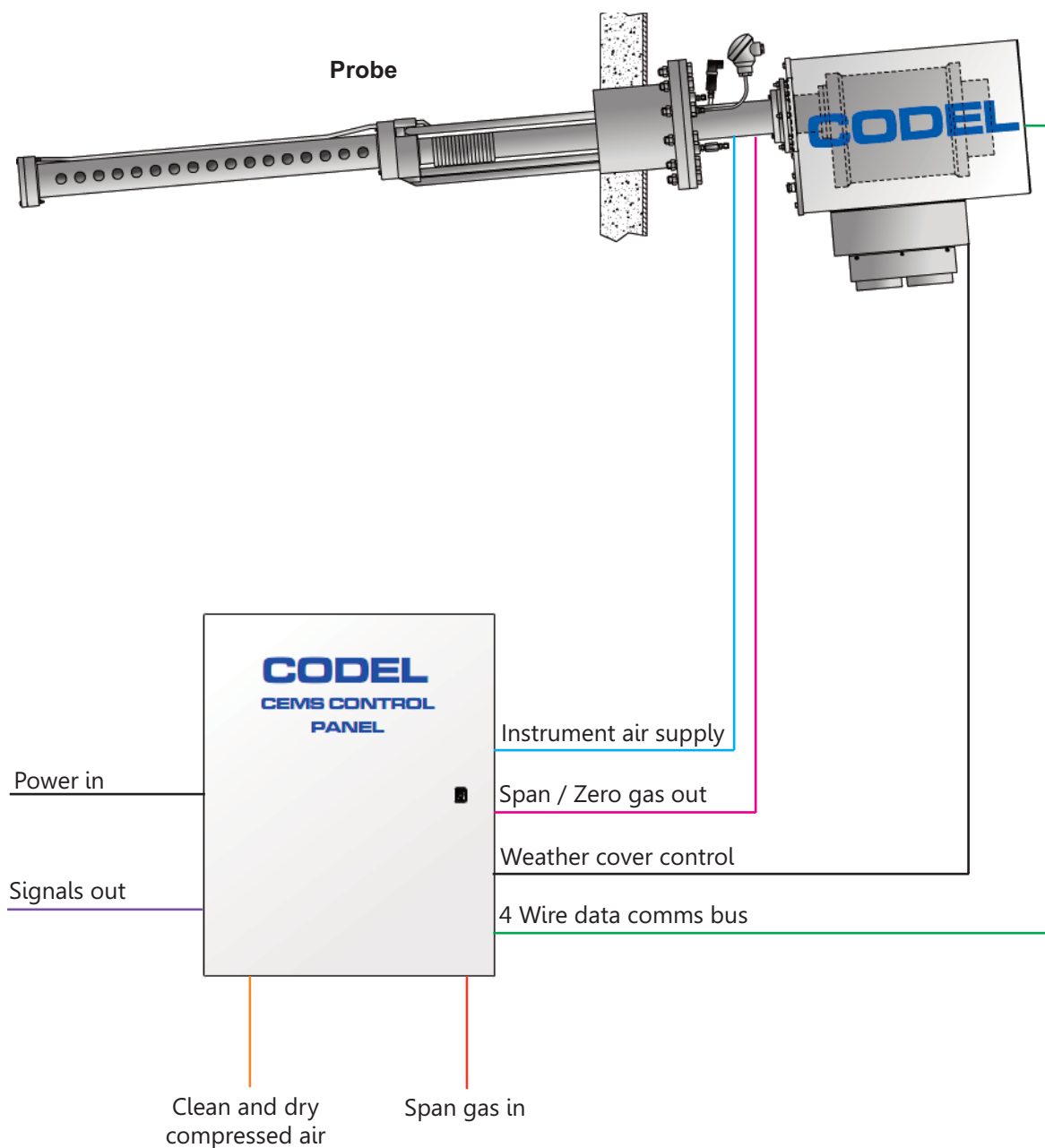

GCEM4000 Gas Analyser - Options



Central Data Controller (CDC)



1. Plug-in 4-20mA Input PCB
2. Plug-in Contact Input PCB
3. RS484 PCB for Modbus Output



CODEL SmartCEM Software

Overall Dimensions - 2.2m Probe

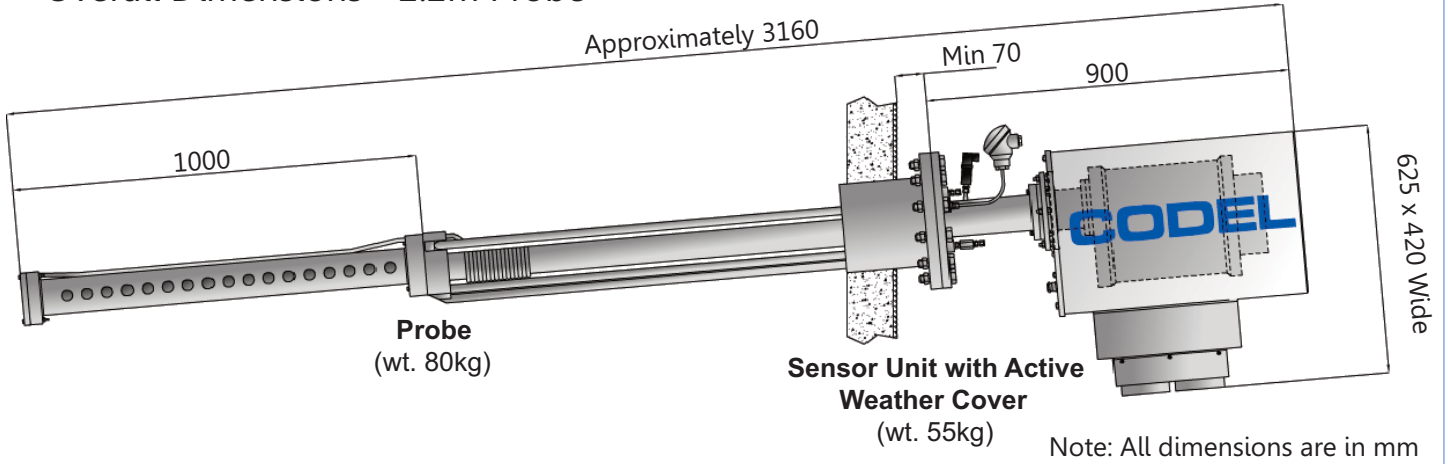

Overall Dimensions - 1.8m Probe

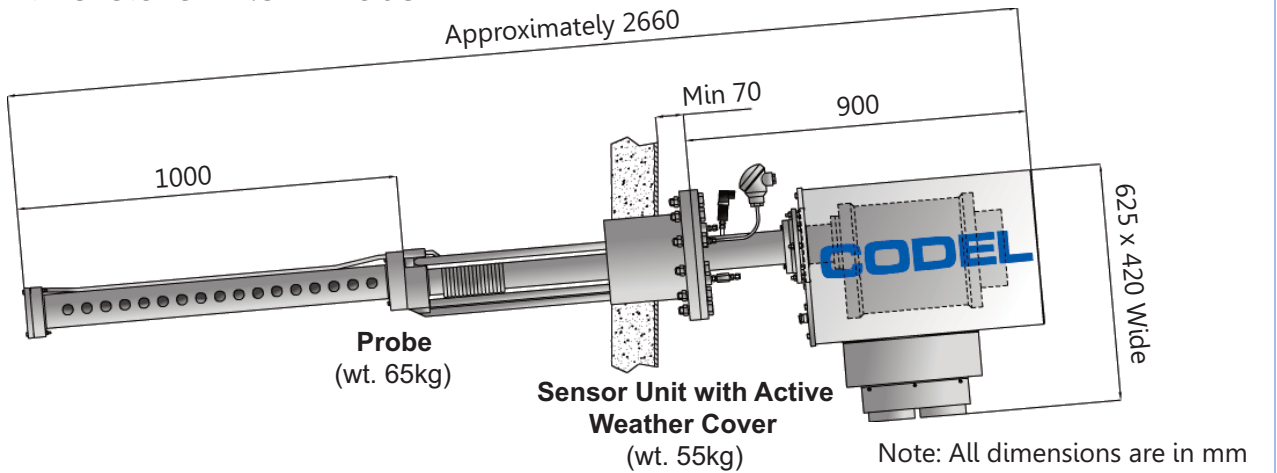

Overall Dimensions - 1.0m Probe

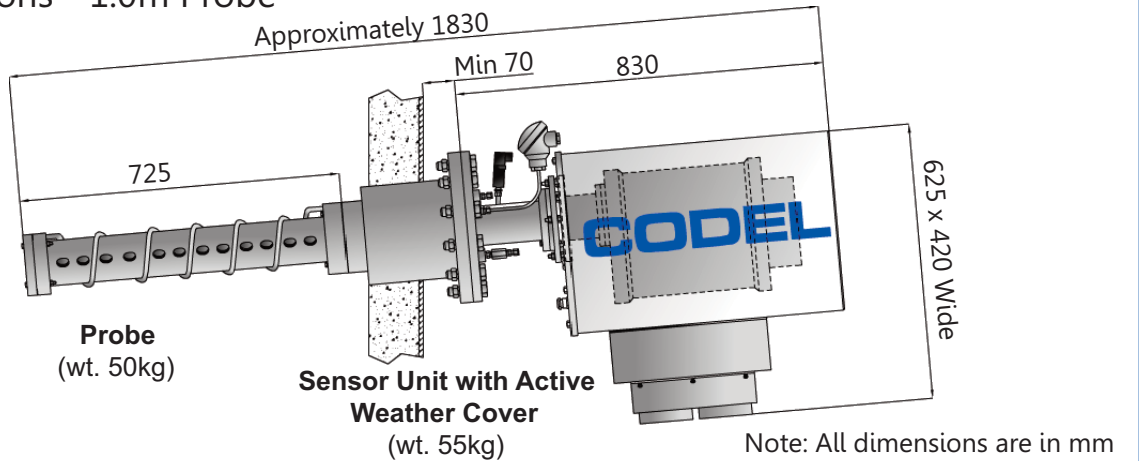

Overall Dimensions - Site Flange

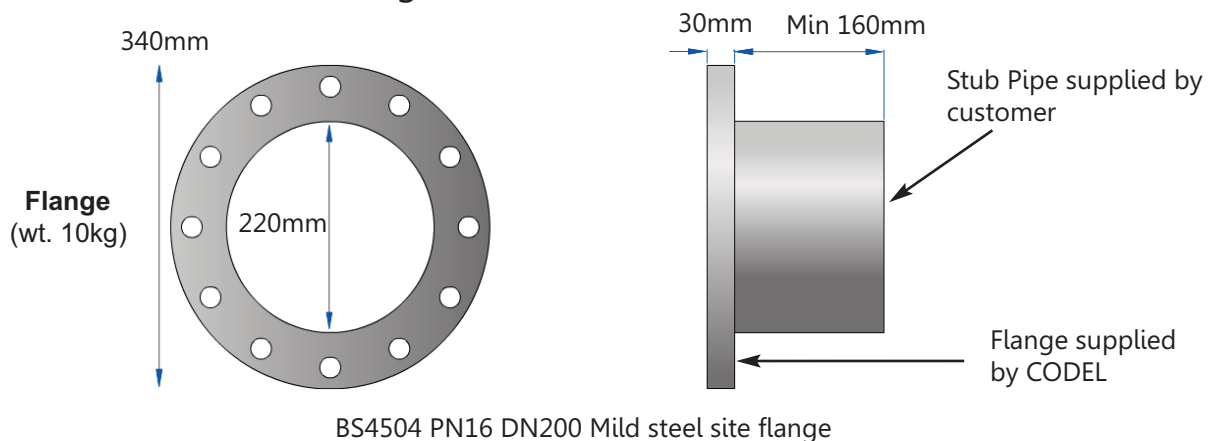

Standard CEMS Control Panel Dimensions

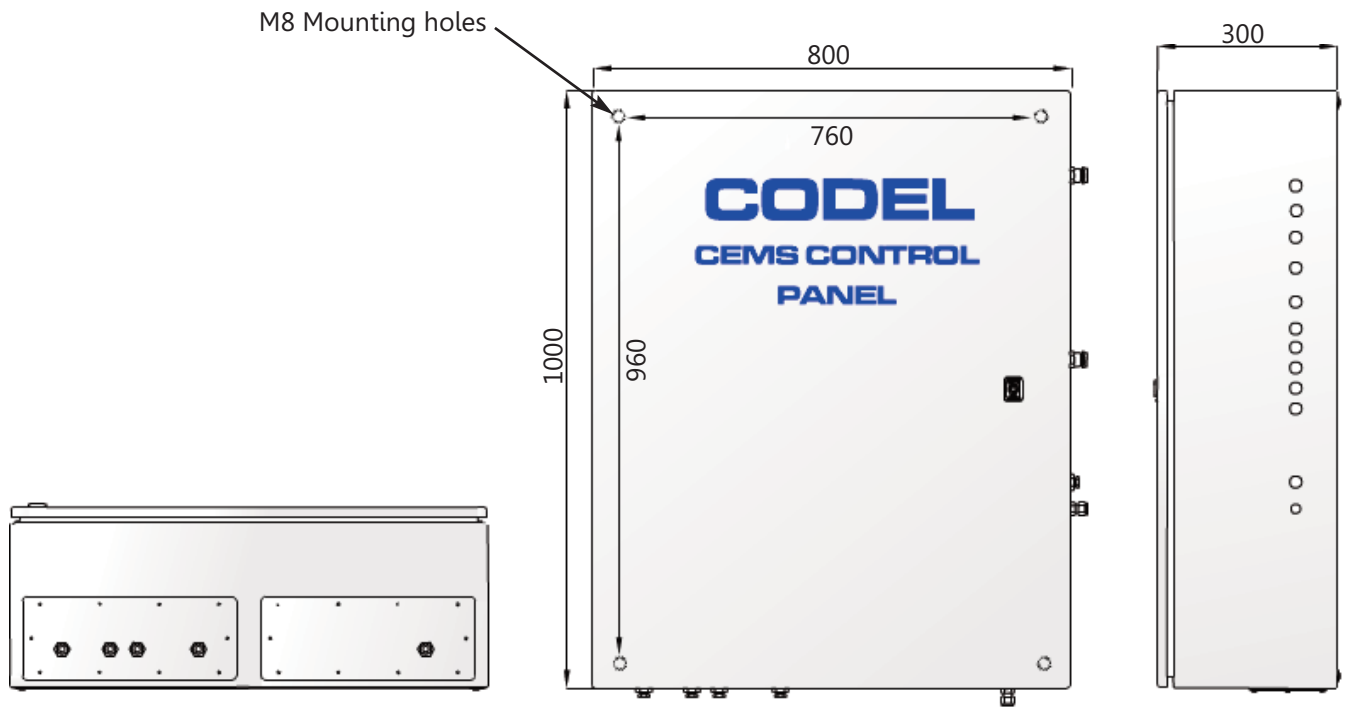

Standard Cems Control Panel

The GCEM4000 CEMS Control Panel houses all auxiliary equipment necessary for the correct function of the analyser. These include: power; input/output connections; purge air supplies; gas calibration pneumatics and the Station Control Unit (SCU).

The epoxy-coated, mild steel enclosure is designed for outdoor use and sealed to IP55 or IP66 . It is perfectly suited for installation at the stack alongside the GCEM4000 Analyser.

Site power is connected via a power isolator and distributed to various functions within the Panel using individual miniature circuit breakers. 48V DC is generated in the Panel for the CODEL Station Control Unit (SCU) and the Analyser.

The SCU is essentially the system computer which controls the flow of data to and from the analyser, initiates zero and span gas calibrations (either automatically or on demand) and produces the current outputs, relay outputs and serial communications. A separate, dedicated RS232 port allows an engineer to connect a portable laptop PC to the SCU to commission the entire system.

The SCU is designed with plug and play PCB cards offering complete flexibility for input and output options.

A compact Air Dryer Unit is installed inside the panel to condition the site compressed air until it is clean, oil-free and dry to – 20 deg C. Other integral pneumatic devices control the clean air to the GCEM4000 probe for purging and for zero gas calibrations. There is also a facility for introducing protocol gases to the probe to verify the performance of the Analyser.

CODEL CEMS Control Panels can be custom designed to incorporate other CODEL analysers such as dust and flow monitors along with other manufacturers' oxygen analysers. This ensures the installation is compact and electrical and mechanical works are kept to a minimum.

SmartCEM Software

- Detailed and customisable reports to meet Regulatory Agency requirements (including LCPD, WID)
- User configurable real-time and historical graphing facilities for data analysis
- Data export to popular applications such as Excel etc
- Multi-user networking capability
- Real-time normalisation of data
- Satisfies EN14181 QAL3 requirements
- Data storage on PC hard drive of at least 10 years
- Easy installation and set-up
- Intuitive operation
- Will operate on Windows based operating systems

SmartCEM Emissions Monitoring Software provides the complete solution to data gathering and analysis on CODEL-based monitoring systems. With a simple installation and set-up routine, the program takes only minutes to load and configure and comes with a comprehensive on-board help feature.

Real-time Displays

Using a serial link to communicate with the sensors, SmartCEM updates the live data screen every 30 seconds to keep the user aware of the current situation on plant, while alarms warn the operator of high emission levels.

Data is displayed in numerous formats - ppm, %, mg/Nm³, mg/m³, kg/hr assuming flow measurement is available etc. - and the change of format is instantaneous.

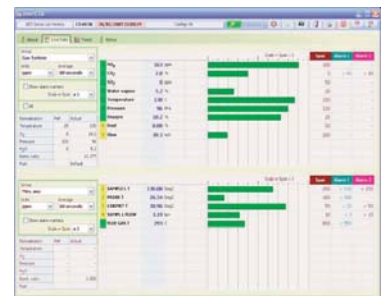

Graphs

A key feature of SmartCEM is the provision of real-time and historical graphs providing detailed analysis of emissions data. One useful feature enables the user to highlight a period of time on the graph and obtain the average emissions. Data is easy to read and is configurable to individual operator requirements.



GSM Unit

The GSM unit allows CODEL engineers direct access to any analyser in our range giving them full online remote diagnostic information for technical support.*

This service can be offered for a nominal monthly charge

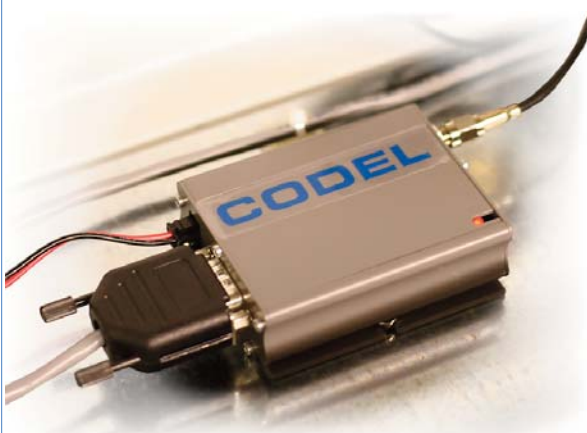

* Network coverage can limit the use of this service

GCEM4000 Multi-Channel Gas Analyser - Technical Specification

Sensor Unit

Gas Species Options	Maximum 7 gases from: CO, NO, NO ₂ , NO _x , N ₂ O, SO ₂ , HCl, CH ₄ and CO ₂ Gas temperature, pressure and H ₂ O for data normalisation are standard.	
Measuring units	ppm, mg/Nm ³ , mg/m ³ , %	
Response Time	Less than 200 Seconds (T90)- MCERTS Specification	
Gas Temperature	Standard probe - dewpoint to 300°C High-temp probe - dewpoint to 400°C (Other temperatures available on request)	
Calibration	Automatic and manual zero/span verification	
Gas Species	CO, NO, NO ₂ , NO _x , SO ₂ , CH ₄ , HCl	CO ₂ , H ₂ O
Max Measuring Range	0 - 6000 ppm, higher ranges available on request	0 - 25%
Accuracy	+/- 2ppm or 2% of span	0.5% or 2% of span
Resolution	+/- 1ppm	0.1%
Zero & span drift	+/- 2ppm or 2% of span per month	0.5% or 2% of span
Linearity	+/- 2% of span	2% of span
Repeatability	+/- 5ppm or 1% of span	0.3% or 1% of span
Ambient Temperature	-20°C to +50°C	
Power supply	48V DC from CEMS Control Panel	
Construction	Corrosion resistant epoxy coated aluminium housing sealed to IP66	

Probe

Length	1.0m, 1.8m & 2.2m
Construction	316L stainless steel with 20 µm sintered filters

Compliances

EMC	89/336/EEC directive compliant
Low Voltage	73/23/EEC directive compliant
MCERTS	Certified product CO, NO, NO ₂ , SO ₂ & H ₂ O - See Sira certificate MC070098/03

CEMS Control Panel

Analogue outputs	4-20mA current outputs for each gas channel supplied, isolated, 500Ω load max, fully configurable from software.
Logic Outputs	up to 8 x volt-free SPCO contacts, 50V, 1A max, configurable as alarm contacts 1 x volt-free SPCO contact, 50V, 1A max, for data valid signal
Inputs	1 x 4-20mA for oxygen
Serial Data	RS232
Construction	Mild steel construction powder coated to IP66 or 55 (Single door/Double door)
Ambient Temperature	-20°C to +50°C
Power Supply	90 - 132VAC or 180 - 264VAC by switch
Air Dryer	For clean, dry, oil-free air

Services

Power	Mains 110/230 VAC, single phase, 50/60hz
Air Requirement	Clean and dry compressed air @ 4bar Consumption during normal operation 5 litre/min, during calibration 30 litre/min.

Optional Items

Central Data Controller	For connection to additional SmartCEM systems
Plug-in PCB	4 - 20mA Input PCB
Plug-in PCB	Contact input PCB
Plug-in PCB	RS485 PCB for Modbus Output
Software	CODEL SmartCEM Software - See SmartCEM software data sheet

CODEL International Ltd
Station Building
Station Road
Bakewell
Derbyshire
DE451GE
United Kingdom

Tel : +44 (0)1629 814351
Fax : +44 (0)8700 566307
Web : www.codel.co.uk
Email : sales@codel.co.uk

Distributor