



## Continuous Emission Monitoring

GCEM 40 Series Gas Analyser

CO, NO, NO<sub>2</sub>, NO<sub>x</sub>, SO<sub>2</sub>, CH<sub>4</sub>, CO<sub>2</sub> & H<sub>2</sub>O

**In-situ low cost, low maintenance devices for continuous process and emissions monitoring.**

- Single or Multi-species infrared absorption analyser - Accurate, reliable and low maintenance technology
- In-situ stainless steel probe measurement - Single unit install. No sample lines required
- Gas temperature and pressure sensors - On-board normalisation to standard reference conditions
- Auto routine calibration - Zero and span calibration using audit gas
- Analogue and serial outputs - Export of data to SCADA, DCS and historian systems



## GCEM 40 Series Gas Analyser

The GCEM40 series is the latest generation of CODEL's world renowned in-situ monitors. Our development, knowledge and practical experience have been utilised to produce this advanced technology gas analyser which gives complete flexibility of use on process or emissions applications whilst delivering superb accuracy and repeatability at a very competitive price.

The analyser uses a field proven in-situ 316 stainless steel probe designed for the harshest stack conditions to measure directly in the flue stream. The design of the probe enables accurate measurements to be made even in very high dust level processes exceeding several  $\text{g}/\text{m}^3$ .

Designed for use primarily on combustion processes, the GCEM40 series measures key pollutants such as  $\text{CO}$ ,  $\text{NO}$ ,  $\text{NO}_2$ ,  $\text{NO}_x$ ,  $\text{SO}_2$ ,  $\text{CH}_4$ ,  $\text{CO}_2$  and  $\text{H}_2\text{O}$  using an infra-red spectroscopy to ensure that there is no cross sensitivity from other contaminants in the gas stream. The GCEM40 series analysers can be configured in either single or multi-gas mode to give operators a full range of options.

Fully automated zero and span calibrations are performed using clean dry compressed air and protocol gas mixtures to provide long-term accuracy along with minimal maintenance requirements. Pneumatics mounted directly on the measurement probe allow both zero and span gas to be injected into the measurement chamber either manually, automatically or remotely.

All models are fitted with a probe mounted temperature sensor. As an additional option pressure,  $\text{CO}_2$  and  $\text{H}_2\text{O}$  can be measured to provide fully normalised data in  $\text{mg}/\text{Nm}^3$ .

The GCEM40 Series analyser is available with either a single species measurement for process control or with multi-species measurements for a choice of emissions monitoring.



Data Display Unit (DDU)



Air Dryer Unit (optional)



Stainless Steel 316l Probe

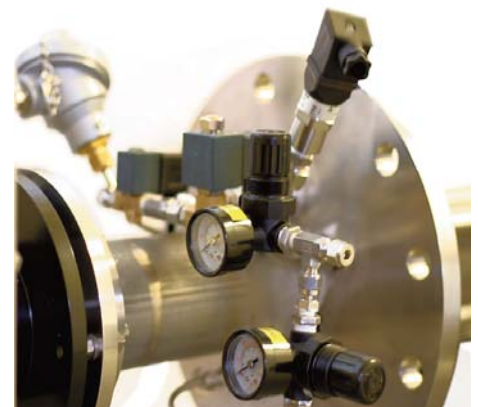

GCEM 40 Series pneumatics

## GCEM 40 Series Gas Analyser - System Arrangement

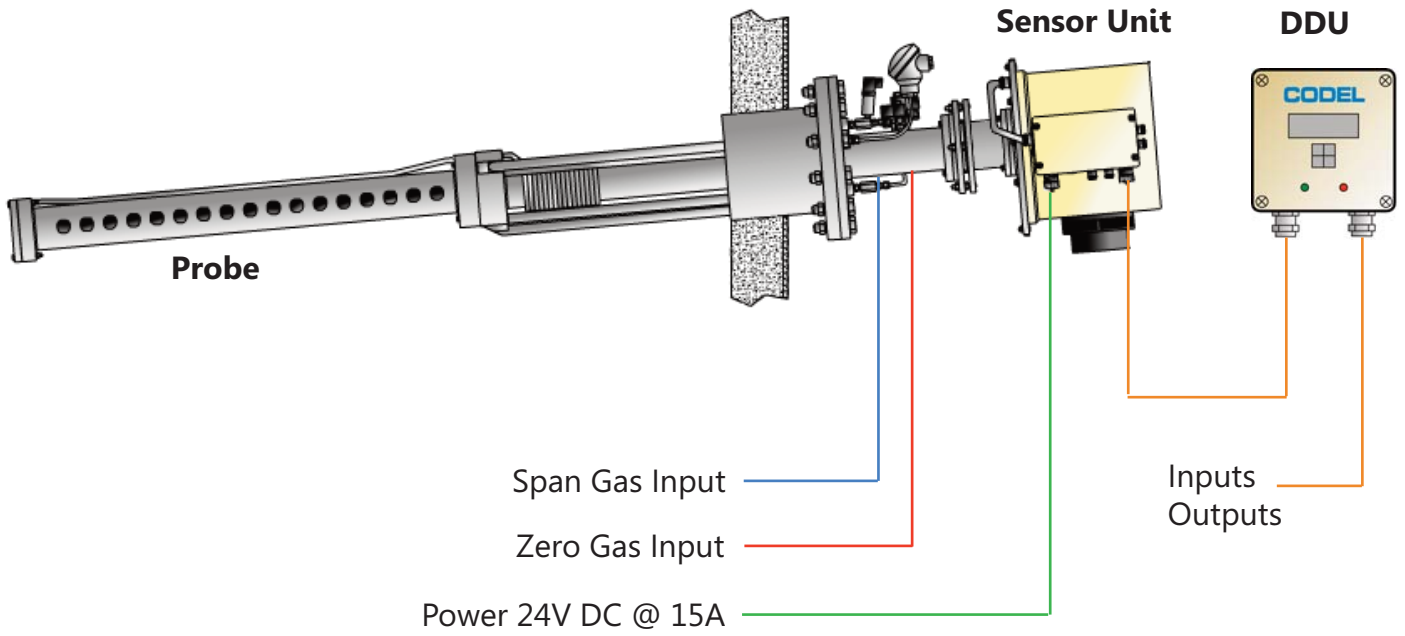

## GCEM 40 Series Gas Analyser - Options



24V DC Power Supply  
Mains in 110 / 220 VAC



For clean/dry oil-free air to -20°C



Larger DDU for 5 x current outputs

### Overall Dimensions - 2.2m Probe

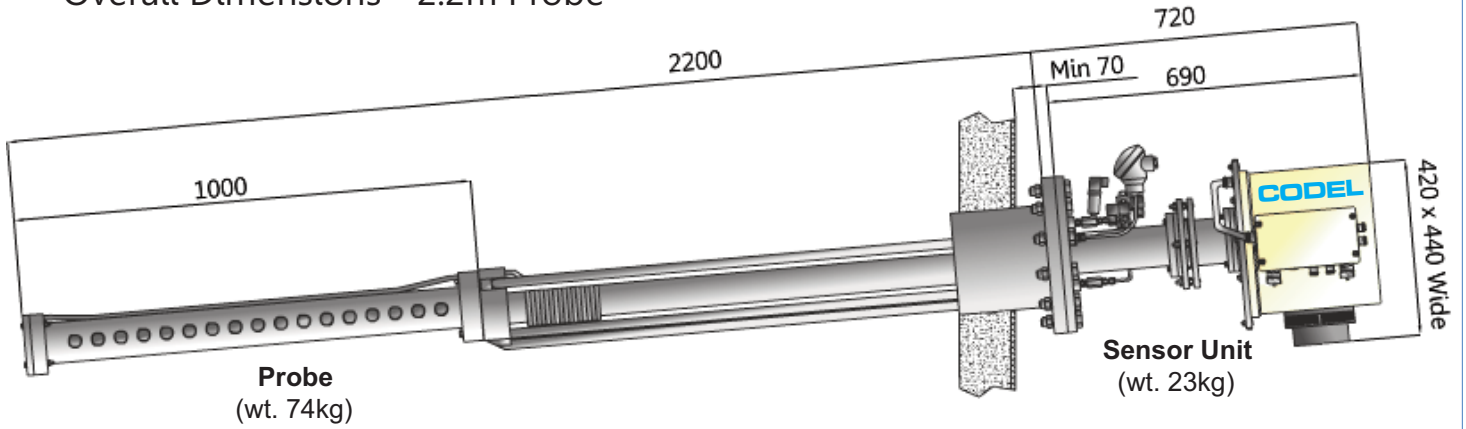

Note: All dimensions are in mm

### Overall Dimensions - 1.8m Probe

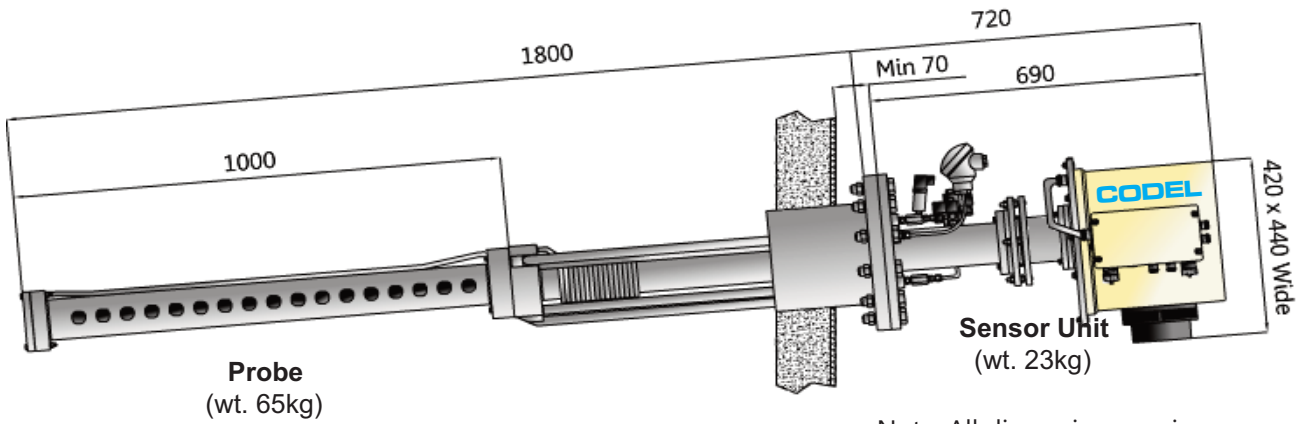

Note: All dimensions are in mm

### Overall Dimensions - 1.0m Probe

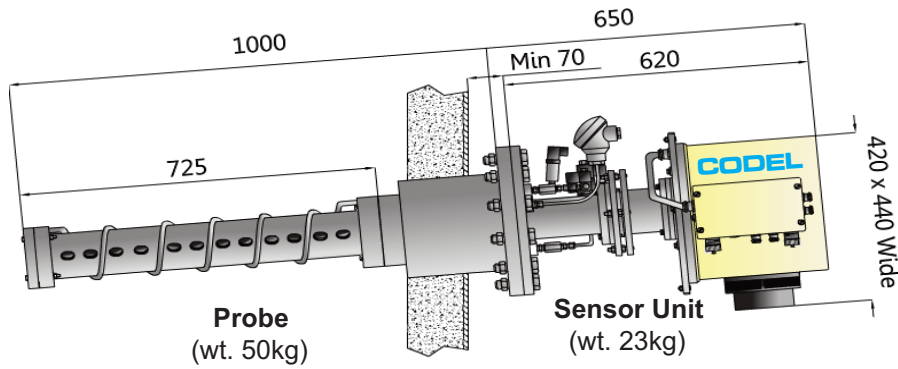

Note: All dimensions are in mm

### Overall Dimensions - Site Flange and Data Display Unit

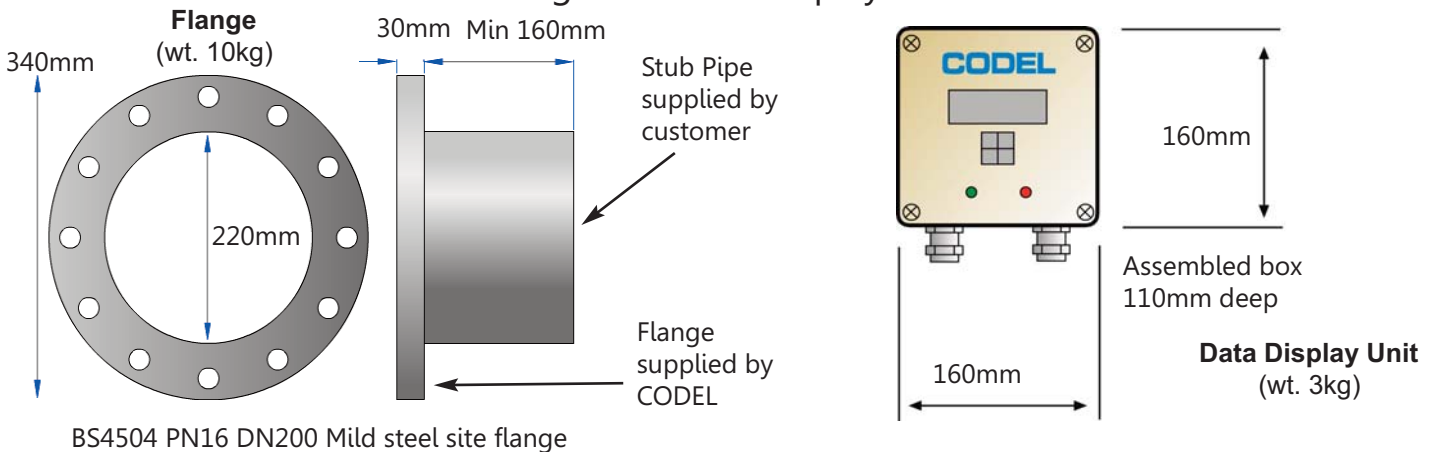



## SmartCEM Software

- Detailed and customisable reports to meet Regulatory Agency requirements (including LCPD, WID)
- User configurable real-time and historical graphing facilities for data analysis
- Data export to popular applications such as Excel etc
- Multi-user networking capability
- Real-time normalisation of data
- Data storage on PC hard drive of at least 10 years
- Easy installation and set-up
- Intuitive operation
- Will operate on Windows based operating systems

SmartCEM Emissions Monitoring Software provides the complete solution to data gathering and analysis on CODEL-based monitoring systems. With a simple installation and set-up routine, the program takes only minutes to load and configure and comes with a comprehensive on-board help feature.

### Real-time Displays

Using a serial link to communicate with the sensors, SmartCEM updates the live data screen every 30 seconds to keep the user aware of the current situation on plant, while alarms warn the operator of high emission levels.

Data is displayed in numerous formats - ppm, %, mg/Nm<sup>3</sup>, mg/m<sup>3</sup>, kg/hr assuming flow measurement is available etc. - and the change of format is instantaneous.



### Graphs

A key feature of SmartCEM is the provision of real-time and historical graphs providing detailed analysis of emissions data. One useful feature enables the user to highlight a period of time on the graph and obtain the average emissions. Data is easy to read and is configurable to individual operator requirements.



## GSM Unit

The GSM unit allows CODEL engineers direct access to any analyser in our range giving them full online remote diagnostic information for technical support.\*

This service can be offered for a nominal monthly charge

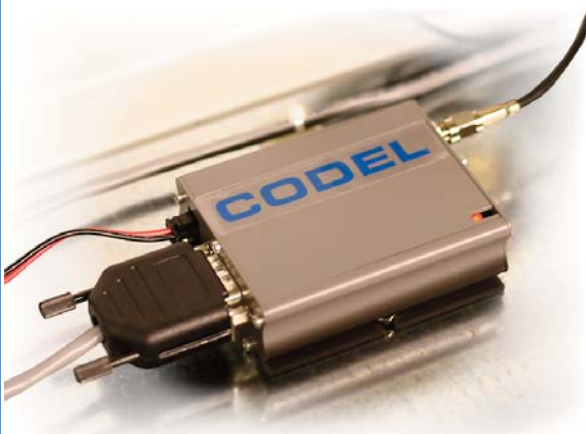

\* Network coverage can limit the use of this service

# GCEM 40 Series Gas Analyser - Technical Specification

## Sensor Unit

Gas Species Options	Single or multi-gas measurements available: Maximum 3 gases from: CO, NO, NO <sub>2</sub> , NO <sub>x</sub> , SO <sub>2</sub> , CH <sub>4</sub> plus gas temperature Plus optional : CO <sub>2</sub> , H <sub>2</sub> O, pressure for data normalisation	
Measuring units	ppm, mg/Nm <sup>3</sup> , mg/m <sup>3</sup> , %	
Response Time	Less than 200 Seconds (T90)	
Gas Temperature	Standard probe - dewpoint to 300°C High-temp probe - dewpoint to 400°C (Other temperatures available on request)	
Calibration	Automatic and manual zero/span verification	
Gas Species	CO, NO, NO <sub>2</sub> , NO <sub>x</sub> , SO <sub>2</sub> , CH <sub>4</sub>	CO <sub>2</sub> , H <sub>2</sub> O
Max Measuring Range	0 - 6000 ppm	0 - 25%
Accuracy	+/- 10ppm or 2% of span	0.5% or 2% of span
Resolution	+/- 1ppm	0.1%
Zero & span drift	+/- 10ppm or 2% of span	0.5% or 2% of span
Linearity	+/- 2% of span	2% of span
Repeatability	+/- 5ppm or 1% of span	0.3% or 1% of span
Ambient Temperature	-20°C to +50°C or 0°C to +70°C	
Power supply	24V DC @ 15A	
Construction	Corrosion resistant epoxy coated aluminium housing sealed to IP66	

## Probe

Length	1.0m, 1.8m & 2.2m
Construction	316L stainless steel

## Compliances

EMC	89/336/EEC directive compliant
Low Voltage	73/23/EEC directive compliant

## Data Display Unit

Analogue outputs	2 x 4-20mA current outputs as standard, isolated, 500Ω load max, fully configurable from keypad (additional outputs available, see optional items below)
Logic Outputs	2 x volt-free SPCO contacts, 50V, 1A max, configurable as alarm contacts 1 x volt-free SPCO contact, 50V, 1A max, for data valid signal
Inputs	1 x 4-20mA for oxygen input (O <sub>2</sub> can also be input at sensor unit) 1 x volt free logic input for plant status or remote calibration initiation
Serial Data	RS232/RS485 (MODBUS protocol)
Display	32 Character alpha-numeric back-lit LCD
Keypad	4-key soft-touch entry
Construction	epoxy-coated aluminium to IP67
Ambient Temperature	-20°C to +50°C
Power Supply	24V DC supplied from sensor unit

## Services

Power	24V DC @ 15A
Continuous Air	Clean and dry compressed air @ 4bar to -20°C Consumption during normal operation 5 litre/min, during calibration 30 litre/min.

## Optional Items

Power Supply	110/220VAC, 50Hz +/- 10%, 400VA to 24V DC @ 15A
Air Dryer	For clean and dry oil free air
Additional Outputs	5 x 4-20mA current outputs isolated, 500Ω load max, fully configurable from keypad

CODEL International Ltd  
Station Building  
Station Road  
Bakewell  
Derbyshire  
DE451GE  
United Kingdom

Tel : +44 (0)1629 814351  
Fax : +44 (0)8700 566307  
Web : [www.codel.co.uk](http://www.codel.co.uk)  
Email : [sales@codel.co.uk](mailto:sales@codel.co.uk)

## Distributor